

# Minicell™

Dissolved air flotation (DAF) clarifier for small flow applications

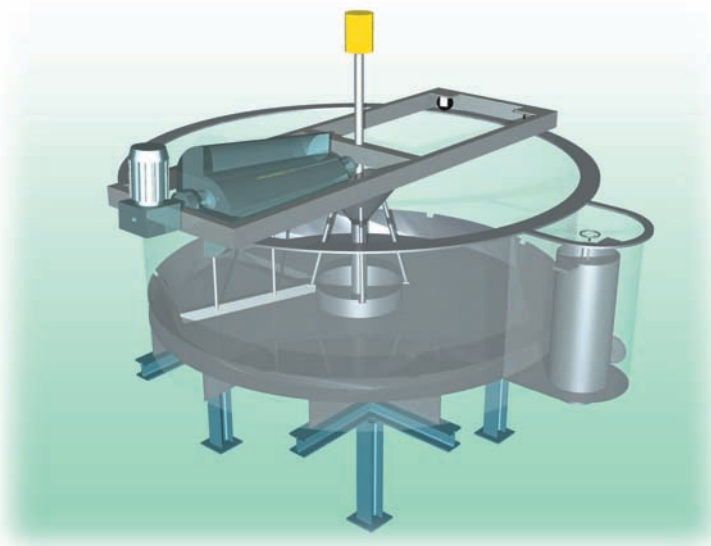

The Minicell is the simplest and the smallest DAF clarifier in the KWI product line. It is designed for small flows.

## Main advantages :

- Very competitive price.
- Simple operation.
- Excellent performance with "difficult" and "fragile" sludge quality - the sludge blanket does not move and the risk of having "sinking flocs" is negligible (the sludge is not pushed to the sludge extraction device as the spiral scoop is travelling around the sludge blanket) .
- 3 different tank heights available (choice according to the application).

## Main applications :

- Excess biological sludge clarification and thickening before further de-watering (for small installations) (excellent application in case of biological phosphorus removal. This reduce also the polymer consumption in the sludge de-watering system).
- Industrial effluents from the food industry in combination with chemical treatment.
- Industrial low flow effluents.

The tank and the construction of the MINICELL can be adapted to the application and to the effluent.

The depth of the tank varies according to the type of the effluent, the inlet solid concentration and the requirements of the application (clarification with or without chemicals, sludge thickening,...)

MINICELL is available in 10 sizes from 16 to 450 m<sup>3</sup>/h.



MNC 12 - Cheese making effluent



MNC 10 - Tannery effluent

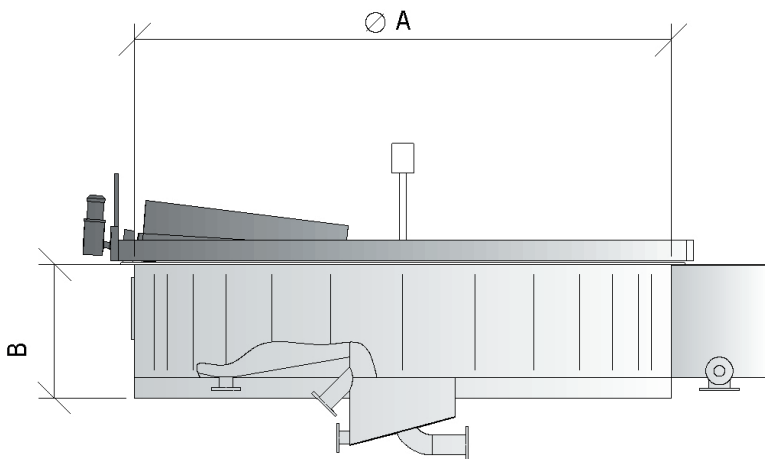

\* The maximum flow includes recycle flow and is dependent on suspended solids loading and the application!

Type	Max. flow (m <sup>3</sup> /h) *	Motor scoop (kW)	Motor carriage (kW)	ø A (mm)	B (mm)	Weight tons (full of water)
MNC 6	16	0,25	-	1850	1000/1500	3/4,3
MNC 8	34	0,25	-	2400	1000/1500	5/7,2
MNC 10	60	0,37	-	3200	1000/1500/2000	8/11,5/15
MNC 12	90	0,55	-	3900	1000/1500/2000	12/18/24
MNC 15	115	0,55	-	4500	1000/1500/2000	15/23/31
MNC 18	180	0,75	0,75	5500	1500/2000	34/46
MNC 20	220	0,75	0,75	6100	1500/2000	42/57
MNC 22	250	1,5	1,5	6700	1500/2000	51/68
MNC 24	300	1,5	1,5	7200	1500/2000	60/85
MNC 30	450	2,2	2,2	9000	1500/2000	108/140

Copyright KWI International Environmental Treatment GmbH. All Rights Reserved. No part of this material and/or brochure/catalogue may be reproduced, stored in a retrieval system, or transmitted in any form or by any means, electronic, mechanical, photo-copying, recording or otherwise, without the prior permission of KWI International Environmental Treatment GmbH. All trademark, marks, indicia, logo, trade name, brand name contain in this brochure/catalogue belong to KWI International Environmental Treatment GmbH.

KWI - Headquarters  
 KWI International Environmental Treatment GmbH  
 Auengasse 8 - A-9170 Ferlach - Austria  
 Tel. : +43 4227 3266 - Fax : +43 4227 3449  
 E-mail : office-at@kwi-intl.com



www.kwi-intl.com



ISO 9001 / 14001 CERTIFIED

Copyright © KWI International Environmental Treatment GmbH.  
 All Rights Reserved.

No part of this material and/or brochure/catalogue may be reproduced, stored in a retrieval system, or transmitted in any form or by any means, electronic, mechanical, photocopying, recording or otherwise, without the prior permission of KWI International Environmental Treatment GmbH.

All trademark, marks, indicia, logo, trade name brand name contain in this brochure/catalogue belong to KWI International Environmental Treatment GmbH.